



NATCEM 35

Description

NATCEM 35 is a fast setting and fast curing mortar with a rapid strength gain that is resistant to chloride penetration, consisting of a blend of NATCEM Reg.31 Cement Binder, specially selected dried graded aggregates all passing a 2mm sieve and retarders.

Uses

- Waterproof renders
- Work in and around sewers
- Industrial floor repairs
- Work in food factories
- Concrete repair
- Work in and around the sea
- Animal sheds and silage pits
- Garage pits
- Basement tanking
- Farm yards and cess pits
- Pipe joints and benching
- Sealing garage pits
- Fast general repairs and construction work
- Work wherever pollution or chemical attack is likely
- Overhead and horizontally

- Setting holding down bolts
- Floor screeds
- Bedding blocks
- Stone and bricks
- In contact with potable water
- Fine moulding.

Properties

- Fast setting
- Excellent adhesion
- Low shrinkage
- Low modulus of elasticity makes it very effective on poor or friable substrates
- Excellent resistance to pure water and sulphated water
- Excellent resistance to aggressive chemicals
- Very good cohesion and mixing
- Fine compact surface
- No curing necessary. It can be coated, covered or painted as soon as setting is complete
- Can be used in wet conditions
- Can be used under water
- High Strength
- Low carbon dioxide permeability
- Low water permeability.

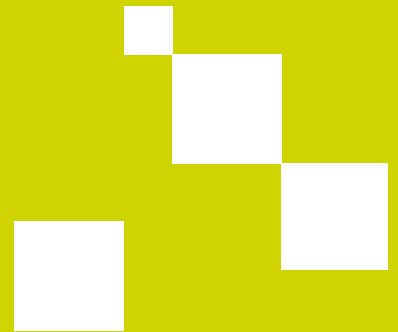



NATCEM 35

Method of use

Preparing the surface

Do not use on frozen or over heated substrates (Outside the range of 0°C-30°C).

Prepare the surface in advance ensuring it is well roughened to provide an adequate key.

Any adhesion reducing substances such as oil, paint, bitumen, grease or laitance must be removed by suitable means.

On glazed brickwork the joints should be raked out and the surface bush hammered to form a key. The surface to which the NATCEM 35 is applied should be clean, free from dust and thoroughly dampened. Where necessary steel or aluminium mesh can be used. Ensure that a 10mm minimum thickness of material is obtained.

Priming

There is no need to prime any reinforcement, but if priming is preferred, any conventional system may be used.

Application

Mixing

For optimum results, mix using conventional mixing machines. Always place the water in the mixer or mixing container and add the powder. Gradually add the NATCEM 35 to no more than 3.6 litres of clean water per bag whilst continuously mixing the material. If one bag or less is to be used the NATCEM 35 can be mixed with a rose bud type paddle attached to an electric drill (900rpm, 1000w). Mix vigorously for at least 2 minutes after adding all the mixture to

the water. NATCEM 35 is designed to give a fluid mix but this only develops after sufficient mixing. The mix will appear dry at first. Continue mixing until fluidity develops. If greater fluidity is required, more water up to a total of 4 litres may be used. Exceeding this ratio will lead to lower strength, longer setting time and the risk of surface cracking appearing. In cold weather the set can be accelerated using warm water, likewise in hot weather cold water can be used to slow down the set.

One bag

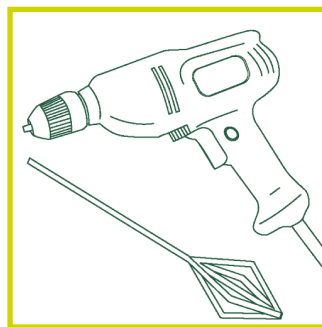

Rose bud paddle in electric drill 900rpm 1000w.

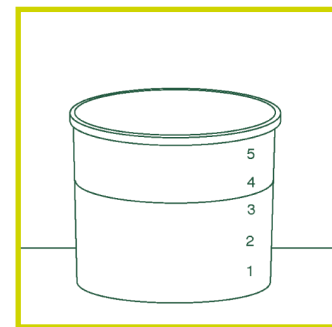

Place 3.6 litres of water into a container.

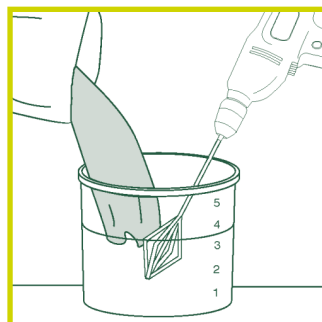

Add the Natcem 35 to water mixing all the time.

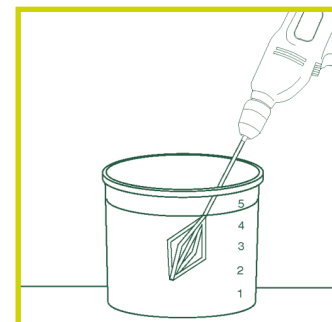

After the NATCEM 35 has been added mix for at least 2 minutes.

General

After mixing, apply the material as quickly as possible after mixing using traditional tools. A 10mm minimum thickness of the material is always necessary. Do not apply additional water to the surface during finishing as this may cause surface cracking. Once setting has started DO NOT attempt to remix or to smooth the surface. This will cause the mechanical properties, in particular strength and adhesion to be lost.

Tanking

Prepare the walls and floor which are to be treated by removing all paint and surface coatings. Cut a chase a minimum of 10mm deep by 10mm wide at all internal angles of the wall to wall and wall to floor joints, then fill with NATCEM 35 as the work proceeds. Form fixing points by cutting out an area at least three times the diameter and one and a half the length of the fixing, filling with the NATCEM 35 as work proceeds but clearly marking the position. Well dampen the surface with water but ensuring no standing water. Mix the NATCEM 35, well dampen the surface again with water, carry out the rendering of the walls using standard and accepted techniques ensuring at all times a minimum thickness of 10mm. Protect against direct sunlight or wind until the setting has completed. Once the NATCEM 35 has set, allow at least 1 hour before applying any surface coatings or covering to the walls or to the floors.

More than one bag

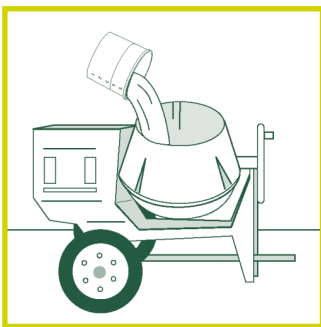

Add water to the mixer at a ratio of 3.6 litres per bag of NATCEM 35.

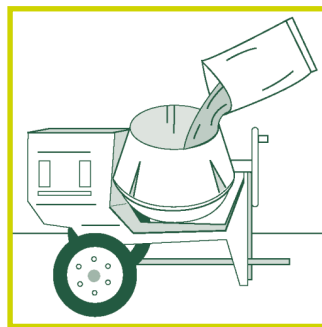

Gradually add the NATCEM 35 to the mixer.

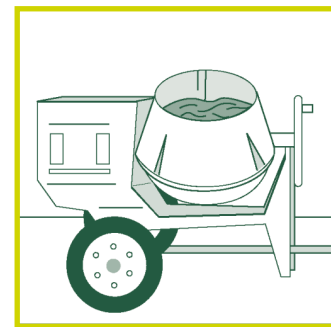

After adding all the NATCEM 35 mix continuously for at least 2 minutes at medium speed.

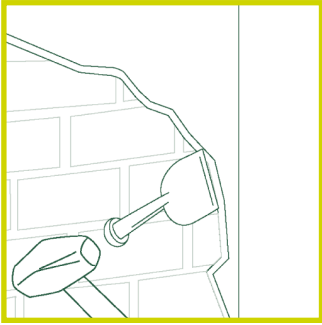

Prepare surface, remove paint, coatings, renders and plaster.

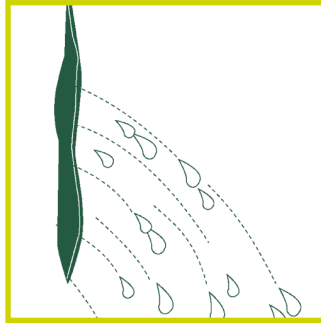

Stop any running water with NATCEM Waterstop. (See separate leaflet)

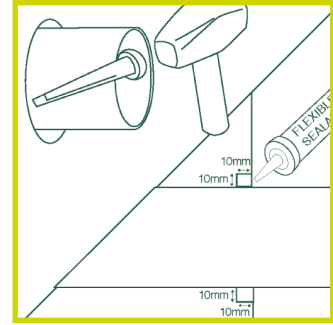

Cut a rebate around any pipe or cable and fill with sealant to form flexible seal around pipe or cable.



Form chase at wall to floor and all internal wall angles minimum 10mm x 10mm.

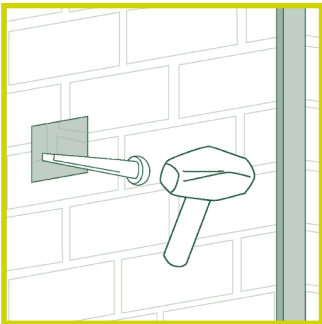
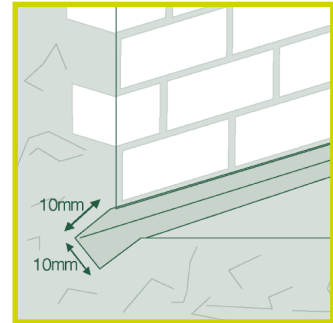
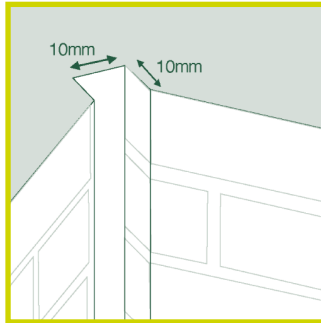

Cut out for fixing point.

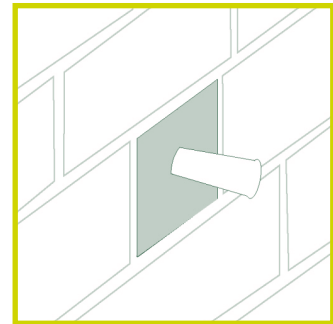
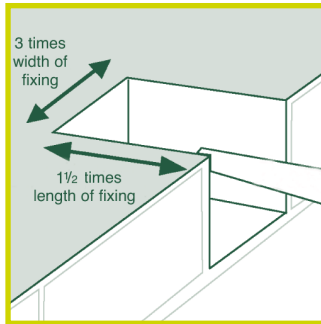

Fill fixing points and clearly mark.

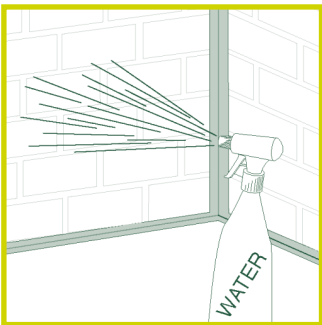

Well dampen surface with water ensuring no standing water.

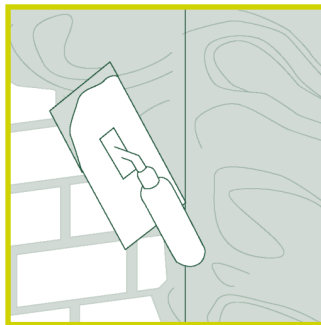

Apply material to wall.

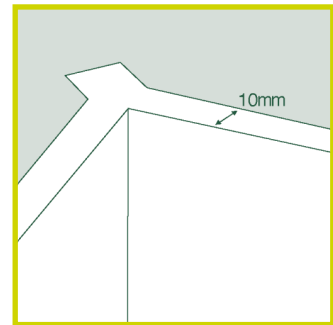

Ensure at all times a 10mm minimum thickness.

NATCEM 35 is a fast setting and fast curing mortar with a rapid strength gain that is resistant to chloride penetration, consisting of a blend of NATCEM Reg.31 Approved Cement Binder, specially selected dried graded aggregates all passing a 2mm sieve and retarders.

Concrete repairs

Remove all loose material from the concrete and the reinforcement. It is only necessary to remove the loose rust from the reinforcement. Prepare the surface as described previously. Fix any necessary replacement

reinforcement and formwork. Well dampen the surface with water ensuring there is no standing water. Mix the material, dampen the surface again and then apply the NATCEM 35 as previously recommended ensuring that the NATCEM 35 is worked around the

reinforcement. Ensure a minimum thickness of material of 10mm at all times. Protect the surface from direct sunlight or wind until setting has completed. Once the NATCEM 35 has set allow at least 1 hour before applying any surface coatings or covering.

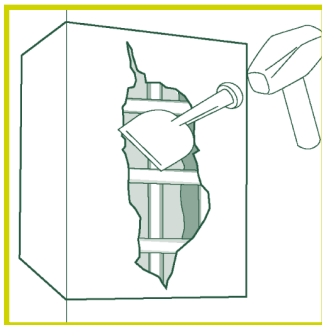

Cut back loose and spalling concrete a minimum depth of 10 mm.

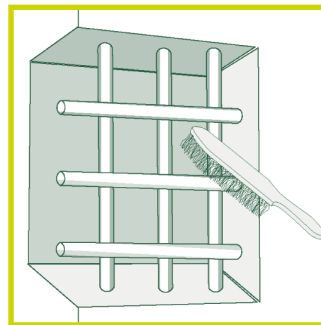

Wire brush any reinforcement to remove any loose rust.

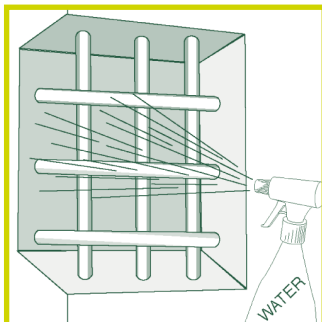

Well dampen the concrete with water ensuring no standing water.

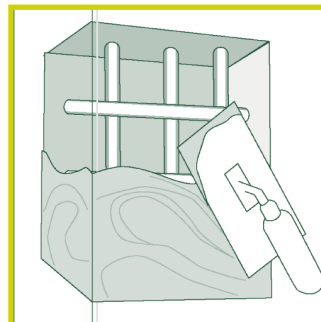

Mix NATCEM 35 as instructed and place the mortar, ensuring at all times a minimum thickness of 10mm.

Setting times

NATCEM 35 is designed to commence setting at 35 minutes and finish setting at 40 mins at 20°C. In winter NATCEM 35 can be used down to 0°C. The set will be slower but can be accelerated by using warm water. In very hot temperatures the set will be faster and can be slowed by using cold water.

Surface Coating Natcem35

When applying finishing plaster to NATCEM 35 we would recommend using Thistle Board-Finish Plaster and not Thistle Multi-Finish

Cleaning

Clean all tools with water immediately after use.

Storage

NATCEM 35 is packaged in a polythene inner bag with a re-sealable tie within a stitch sealed woven polypropylene outer bag that should be stored in dry conditions and will last for at least twelve months.

Yield

Generally 1 x 25kg bag of NATCEM 35 mixed with 3.6 litres of water will produce 10 litres of finished mortar.

How to specify

NATCEM 35 shall be mixed and applied to prepared surfaces all strictly in accordance with the manufacturers instructions.

Precautions

We strongly recommend the use of GLOVES, GOGGLES and MASK. Full details are given on a separate sheet.

Approved for use in public water supplies. Reg.31 Approved

Issue no. 3 - 23/01/23

Setting time & strength gain

Start Set	35 Min	at 20°C
End Set	40 Min	at 20°C
	Flexible Strength (Mpa)	Compressive Strength (Mpa)
1 Hour	2.2	9
3 Hours	2.5	16
24 Hours	3	21
7 Days	4.8	29
28 Days	7	50
Strength continues to develop thereafter.		

Conforms with the requirements of EN1504-3 CLASS R4

Distributed by:



10-11 Fountain Parade, Mappelowell, Barnsley, South Yorkshire S75 6FW

e. enquiries@naturalcement.co.uk t. 01226 381133 f. 01226 381177

www.naturalcement.co.uk