



NATCEM 35

FAST SETTING AND FAST CURING MORTAR

INSTRUCTION FOR USE

ISSUE 3
23 JANUARY 2023

www.naturalcement.co.uk



NATCEM 35 -FAST SETTING and FAST CURING MORTAR

Company Name: Natural Cement Distribution Ltd

Address: 10-11 Fountain Parade
Mapplewell
Barnsley
South Yorkshire
S75 6FW

Telephone: 01226 381133

Fax: 01226 381177

Web: www.naturalcement.co.uk

Contact: Vicki Richardson

e-mail: enquiries@naturalcement.co.uk

This Instructions For Use document is prepared specifically for Water Companies for use with drinking water only



Contents Page

Supplier Details	2
Contents	3
Approval	4
Product Description and Scope of Use	4
Features	4
Packaging and Storage	4
Method of Use	4
Setting Times	9
Strength Gain	9
Cleaning	9
Disinfection	9
Waste Disposal	10
Safety	10



Approval

NATCEM 35 is approved under Regulation 31 of The Water Supply (Water Quality) Regulations 2016.

The product is included in the List of Approved Products for use in Public Water Supply in the United Kingdom.

The List of Approved Products is available on the Drinking Water Inspectorate's website www.dwi.gov.uk/drinking-water-products/approved-products/index.htm.

Product Description and Scope of Use

NATCEM 35 is a fast setting and fast curing mortar with a rapid strength gain that is resistant to chloride penetration. NATCEM 35 consists of a blend of NATCEM drinking water approved cement binder, specially selected dried and graded aggregates all passing a 2mm sieve and retarders.

Features

- Fast setting
- Fast curing
- High strength
- Excellent adhesion
- Low modulus of elasticity excellent for loose or friable substrates
- Low shrinkage
- Excellent resistance to drinking water
- Very good cohesion and mixing
- It can be coated covered or painted within 1 hour after setting
- Can be used in wet conditions
- Can be used under water

Packaging and Storage

Packaging

NATCEM 35 is packaged in a polythene inner bag complete with a re-sealable tie, within a stitch sealed woven polypropylene outer bag. Bag Weight: 25kg



Storage

Unopened bags of NATCEM 35 should be stored in dry conditions and will remain usable for a minimum of 12 months.

Method of Use

Preparing the surface

Do not use on frozen or over heated substrates (outside the range of 7°C - 30°C). Prepare the surface in advance of application to provide an adequate key. On glazed brickwork, the joints should be raked out and the surface bush hammered to form a key. The surface to which NATCEM 35 is applied should be clean, free from dust and thoroughly dampened. Where necessary steel or aluminium mesh can be used. Ensure that a 10mm minimum thickness of material is obtained.

Priming

There is no need to prime any reinforcement, but if priming is preferred, any conventional system may be used.

Mixing

For optimum results prepare the mix using conventional mixing machines. Always place the water in the mixer or mixing container and add the powder.

Gradually add the NATCEM 35 to no more than 3.6 litres of clean water whilst continuously mixing the material.

If one bag or less is to be used the NATCEM 35 can be mixed with a 'rose-bud' type paddle attached to an electric drill (900rpm – 1000w).

Mix vigorously for at least 2 minutes after adding all the powder to the water

One bag

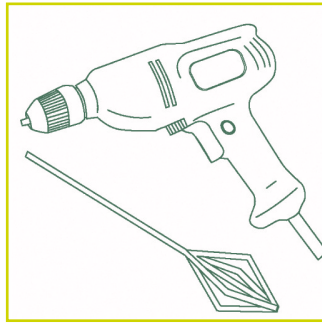

Rose bud paddle in electric drill 900rpm 1000w.

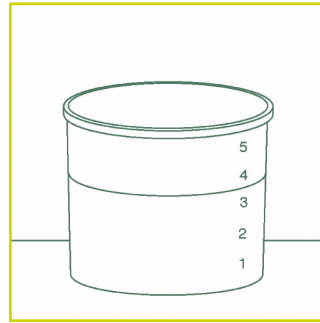

Place 3.6 litres of water into a container.

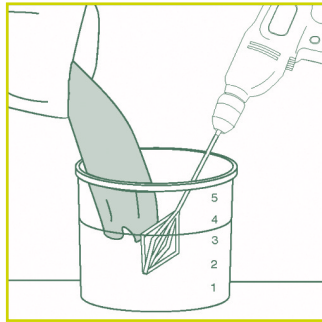

Add the NATCEM 35 to water mixing all the time.

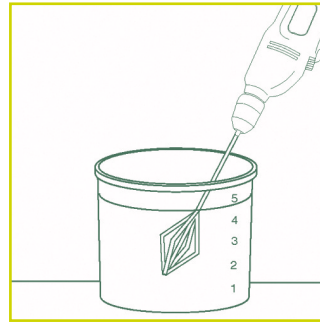

After the NATCEM 35 has been added mix for at least 2 minutes.

NATCEM 35 is designed to give a fluid mix but this only develops after sufficient mixing. The mix will appear dry at first but continue mixing until fluidity develops.

If greater fluidity is required, more water up to a total maximum of 4 litres may be used. Exceeding this ratio will lead to lower strength, longer setting time and the risk of surface cracking appearing. In cold weather, the set can be accelerated using warm water and conversely, in hot weather, cold water can be used to slow down the set.

More than one bag

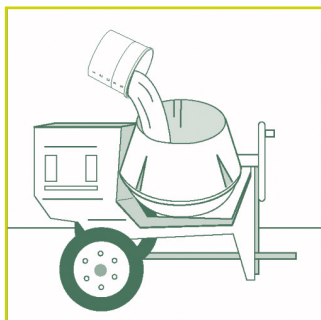

Add water to the mixer at a ratio of 3.6 litres per bag of NATCEM 35.

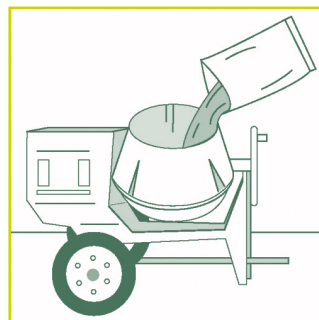

Gradually add the NATCEM 35 to the mixer

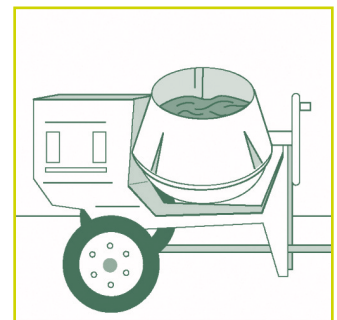

After adding all the NATCEM 35 mix continuously for at least 2 minutes at medium speed

Yield

Generally, 1 x 25 Kg bag of NATCEM 35 mixed with 3.6 litres of water will produce approximately 10 litres of finished mortar.

Application

Carry out the removal of all loose material from the concrete and reinforcement. It is only necessary to remove loose rust from the reinforcement.

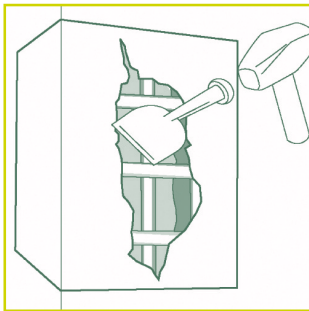

Cut back loose and spalling concrete a minimum depth of 10mm.

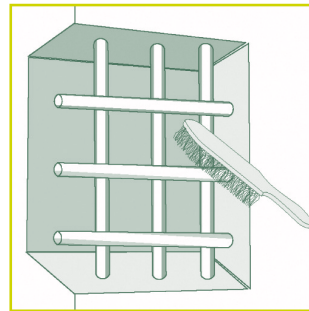

Wire Brush any reinforcements to remove any loose rust.

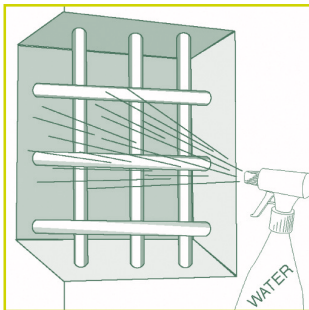

Well dampen the concrete with water ensuring no standing water.

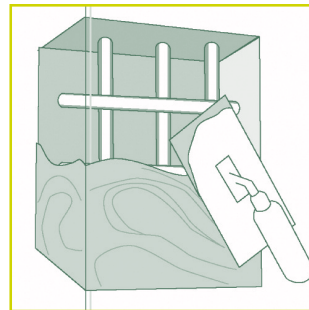

Mix NATCEM 35 as instructed and place the mortar, ensuring at all times a minimum thickness of 10mm.

Prepare the surface as described previously, ensuring the surface is well dampened but also ensuring there is no standing water. Fix any necessary reinforcement, movement joints and formwork. Mix the material and dampen the surface again then apply the NATCEM 35 ensuring it is worked around any reinforcement. Ensure a minimum thickness of material of 10mm is maintained at all times. Apply the material as quickly as possible after mixing, using traditional tools.

- DO NOT apply additional water to the surface during finishing as this may cause surface cracking.
- Once setting has started DO NOT attempt to re-mix or to smooth the surface. This will affect the mechanical properties causing strength and adhesion to be lost. Protect the surface from direct sunlight or wind until setting has completed. Once the NATCEM 35 has set, allow at least 1 hour before applying any surface coatings or covering

Rendering Walls

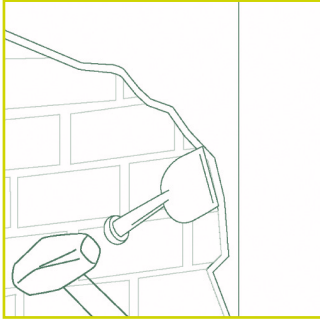

Prepare surface, remove paint, coatings, renders and plaster.

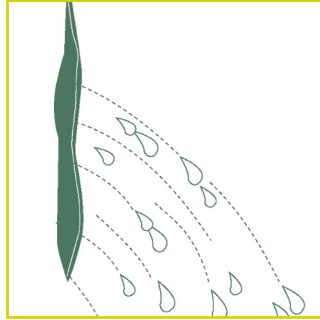

Stop any running water with NATCEM Waterstop. (See separate leaflet)

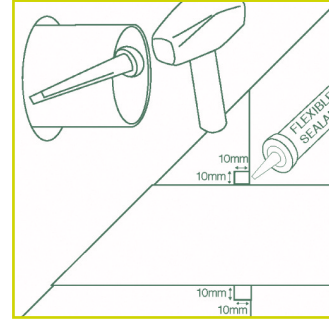

Cut a rebate around any pipe or cable and fill with sealant to form flexible seal around pipe or cable.

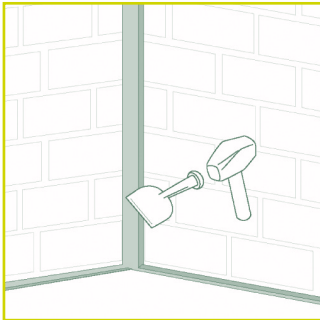

Form chase at wall to floor and all internal wall angles minimum 10mm x 10mm.

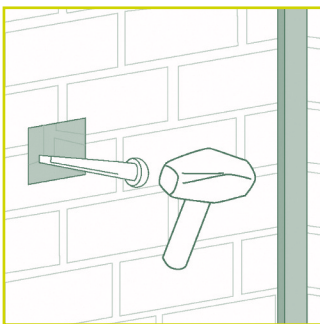
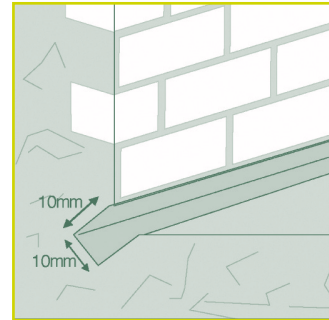
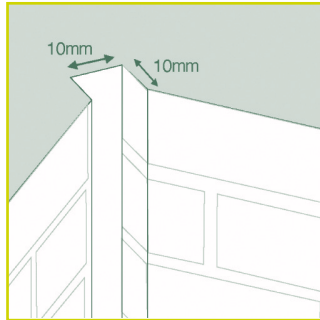

Cut out for fixing point.

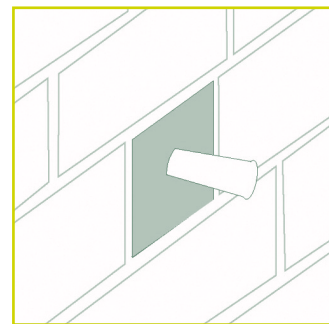
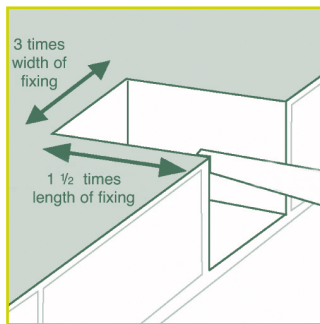

Fill fixing points and clearly mark.

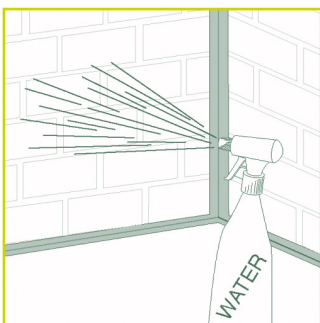

Well dampen surface with water ensuring no standing water

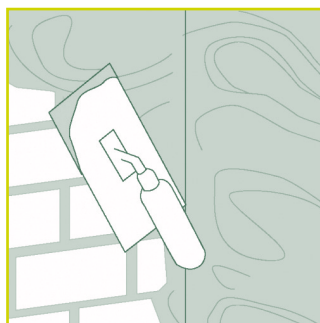

Apply material to wall.

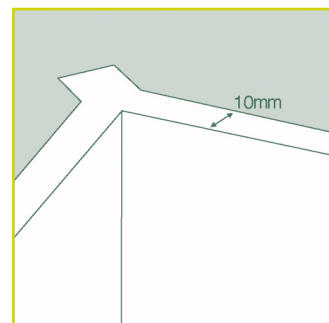

Ensure at all times a 10mm minimum thickness.

Setting Times

Setting time is the time from mixing of the products to its set condition. NATCEM 35 is designed to commence setting at 35 minutes and finish setting at 40 minutes (at 20°C).

In winter NATCEM 35 can be used down to 7°C. The set will be slower but this can be accelerated by using warm water (up to 20°C). In very hot temperatures the set will be faster and can be slowed by using cold water.

After the product has set, a minimum curing time of 1 hr must elapse before returning to service.

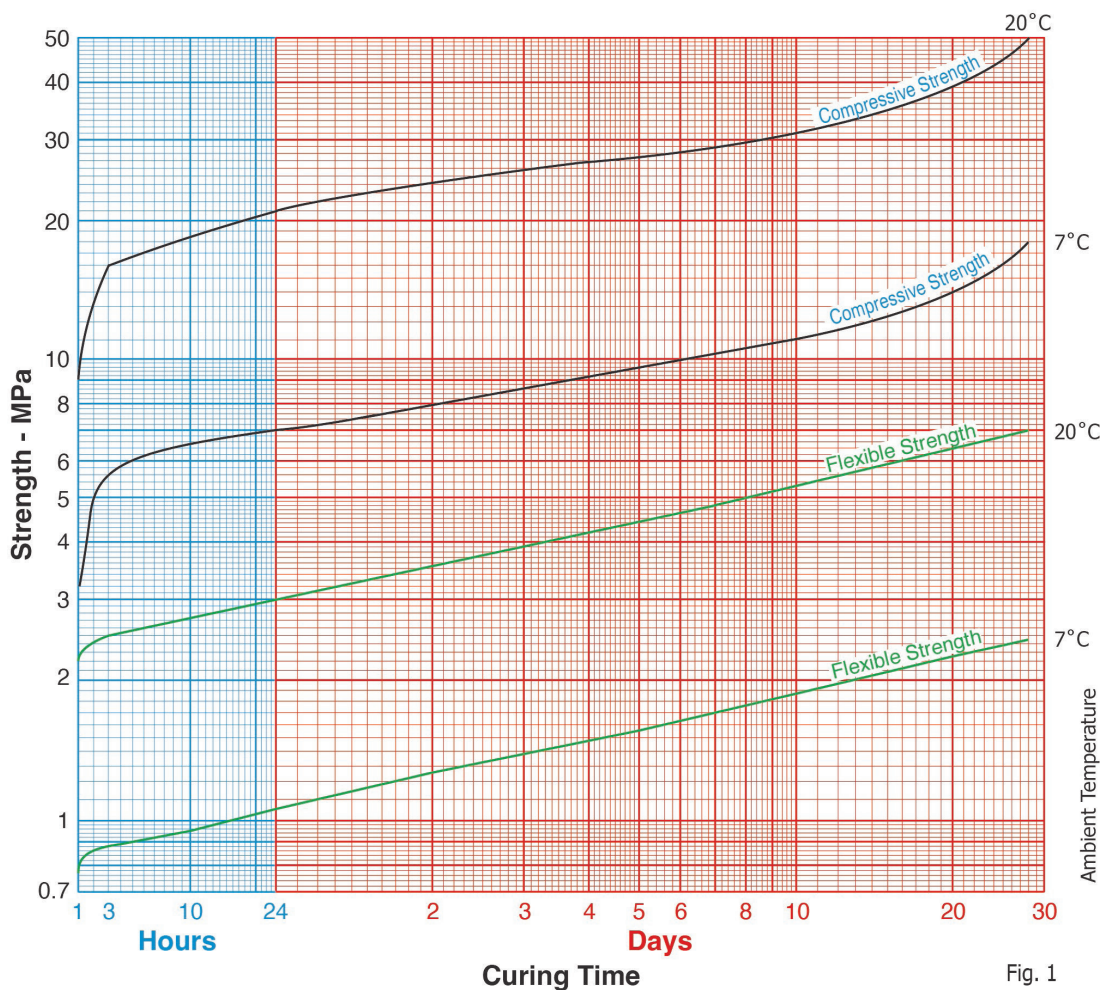

Fig. 1

Strength Gain

After setting is complete the material will continue to gain strength over time. A Flexible Strength gain curve and a Compressive Strength gain curve are shown below (Fig 1). The range shown extends up to 28 days but the strength continues to develop thereafter



Cleaning

NATCEM 35 should be removed from tools and equipment with water immediately after use.

Disinfection

Disinfection of NATCEM 35 is not necessary, the material may be returned to service without further attention. The water utility may, however, wish to introduce a disinfection procedure and further testing prior to return to service at its own discretion.

Waste Disposal

a) Empty bags

Empty polythene inner bags and polypropylene outer bags can be returned to the user's stores for recycling.

Alternatively, they can be disposed of into a skip destined for recycling.

b) Waste material

Dispose of waste material in compliance with local by-laws, national legislation and/or EC regulations

- i. Material after the addition of water – hardened
Dispose of the hardened product as concrete waste. It is a non-hazardous material and may be disposed of in appropriate recycling site
Avoid introduction of this material into sewer systems, waste water disposal networks and water courses
- ii. Material – unused residue or dry spillage
Pick up dry. Mix with water and allow to harden. Dispose of as in 3 b) i above



Safety

- a) Wear suitable protective clothing when handling bags and mixing the material.
- b) Wear safety glasses, work gloves and dust mask.
- c) Avoid spillage from damaged bags.
- d) Avoid breathing the powder.
- e) Avoid raising dust especially when sweeping. Always add the powder to the water to avoid raising dust.
- f) Avoid skin contact with the wet mortar during the setting reaction.
- g) Discard immediately any clothing which becomes saturated with wet cement.

*It is important to read the NATCEM 35 Material Safety Data Sheet (MSDS)
for full details prior to using the material.*

*The MSDS is available on request from Natural Cement Distribution Ltd.
Contact details are shown on Page 2 of these Instructions*



Distributed by:



10-11 Fountain Parade, Mapplewell, Barnsley, South Yorkshire, S75 6FW

e. enquiries@naturalcement.co.uk **t.** 01226 381133 **f.** 01226 381177

www.naturalcement.co.uk